



BE-K
SERIES





BE-K Series

BE-K is a range of e-bike charging stations made of powder coated-steel and characterized by high resistance to UV Rays and an high degree of protection from dust and water.

Equipped with domestic standard socket outlets, they have the sockets compartment, functional in some models to house the battery during recharging operations, protected by a door with key lock or electromagnetic lock with release via RFID.

BE-K Series stations can be managed via Scame's proprietary Management System or can be connected to an external E-mobility service provider via OCPP standard communication protocol.

The clean and essential lines, drawn by Trussardi+Belloni Design, make them the ideal choice in any context.

 technical sheet **p. 6**

Technical information

Main characteristics

PERSONAL and WEB/NET mode

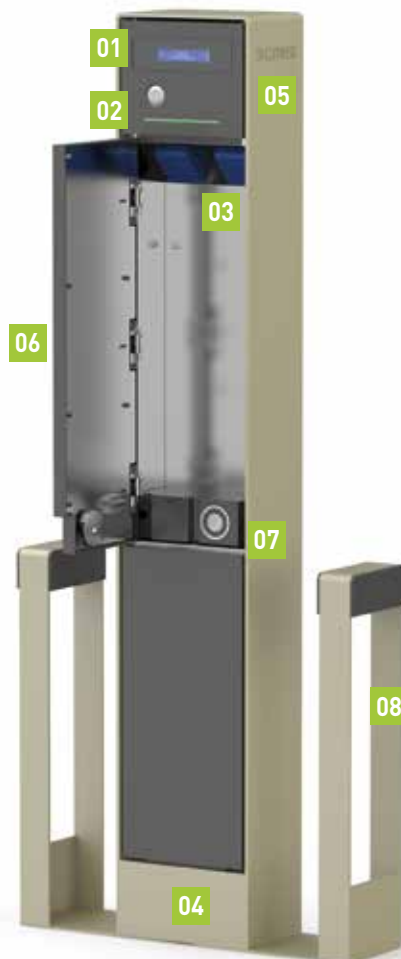

- 01** LCD display interface
- 02** Charging status LED indicator
- 03** IP54 domestic standard socket outlets
- 04** Internal base in stainless steel to prevent condensation from contact with the ground
- 05** Structure in powder-coated aluminium in exclusive colour for Scame
- 06** Possibility of graphic customization on the sockets compartment door **and on the rear panel** (on demand)
- 07** Sockets compartment equipped with magnetic lock (key lock for STANDALONE versions)
- 08** Double bike holder available as an accessory

BE logo

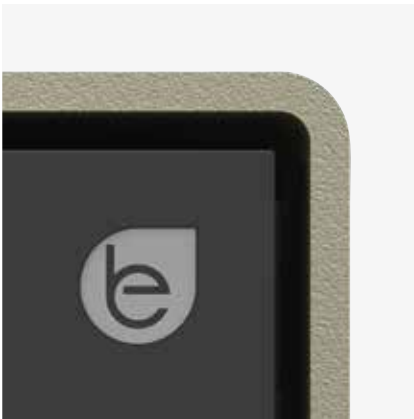

Within the vast offer of Scame Parre, the BE logo, alongside the institutional one, identifies and characterizes the line of products intended for electric vehicles recharging.

By exhibiting it, the stations, the charging cables and the related components are the bearers of over twenty years of company experience in the e-mobility sector, going back to 1999 the presentation by Scame Parre of the first connector specifically designed for this application.

Above all, however, they convey the message behind the logo itself: "Be Eco".

An invitation to embrace a concept of sustainable mobility as an integrated part of a lifestyle that respects man and the environment, rather than a recognition for those who have already done so by choosing one of our products.

A logo in the form of a stylized leaf that, almost resting on the product, leaves an indelible mark on it, adding another chapter to the story of passion, sustainability and innovation from that of Scame.

Application examples



BE-K SERIES

E-BIKE charging stations

STANDALONE MODE



Power	Socket outlet	Display	Access	Digital Energy Meter	Protections	Dimensions (mm)	Compartment dimensions (mm)	Code
3,7Kw	2x Pluristandard P40	-	free	-	RCBO	135x135x902	88x119x224	205.KA09-K
						200x135x1202	88x184x565	205.KC09-K

STANDALONE charging stations represent the highest form of simplicity as they work on a plug and start charging concept. Their straightforwardness delivers an easy and effortless charging experience. Since they are an autonomous solution, they cannot be placed in a Master-Satellite system architecture. On designated products, a key lock can regulate the access to the socket outlets.

PERSONAL MODE



Power	Socket outlet	Display	Access	Digital Energy Meter	Protections	Dimensions (mm)	Compartment dimensions (mm)	Code
3,7Kw	2x German Standard	LCD	RFID	standard	RCBO	200x135x1202	88x184x397	205.KB30-K
						200x135x1352	88x184x547	205.KD30-K

PERSONAL mode charging stations are suitable for installation in all places requiring controlled access insofar as use is not normally limited exclusively to the owners of the vehicle, but rather extends to a greater number of users, or in cases where access to the charging stations needs to be monitored and regulated. PERSONAL mode charging stations can act as a Satellite in a Master/Satellite architecture. Operating mode: Free, Personal (default) Satellite (when connected in a Master-Satellite architecture) Embedded features: Management System (*) Load Balancing (*) OCPP 1.6JSON(*) (*) only available when acting as Satellite in a Master-Satellite configuration in which the Master has activated these features

WEB/NET MODE



Power	Socket outlet	Display	Access	Digital Energy Meter	Protections	Dimensions (mm)	Compartment dimensions (mm)	Code
3,7Kw	2x German Standard	LCD	RFID	standard	RCBO	200x135x1202	88x184x397	205.KB50-K
						200x135x1352	88x184x547	205.KD50-K

WEB/NET mode charging stations are the ultimate choice in all those cases where the system must be monitored and managed remotely. All WEB/NET stations have embedded Scame's proprietary Management System and can act as a Master in a Master/Satellite architecture. A Master station can manage up to 16 charging points. Operating mode: Web/Net (default) Master (when connected in a Master-Satellite architecture) Embedded features: Management System OCPP 1.6JSON Optional features: Load Balancing to be activated during ordering phase via P/N 209.LB01

■ ACCESSORIES



Description	Code
Double bike holder	208.AP82
Anchor plate kit	208.AP83



BE-K SERIES

E-BIKE CHARGING STATIONS



REFERENCE STANDARDS

EN 61439-3

VERSIONS

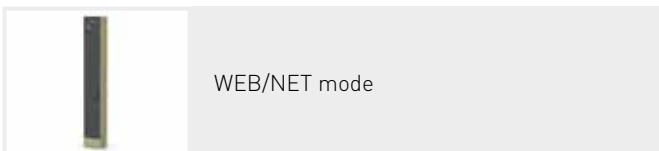
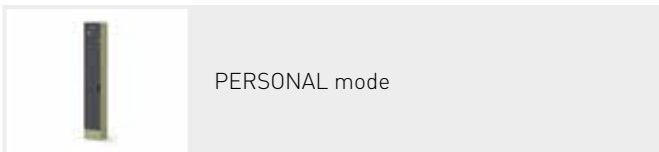
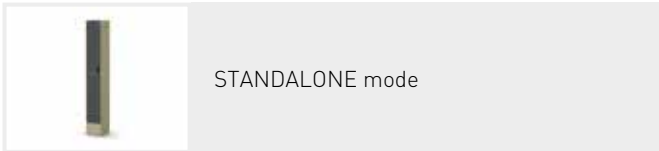

TECHNICAL CHARACTERISTICS

Rated current:	16A
Rated voltage:	230Vac
Frequency:	50/60Hz
Insulating voltage:	250V
Protection degree	IP54
Installation temperature:	-30°C +50°C
Material:	Aluminium
Impact resistance (IK degree):	IK10
Colour:	Bronze
Salt mist:	Resistant
UV radiation:	Resistant

Code 205.KA09-K

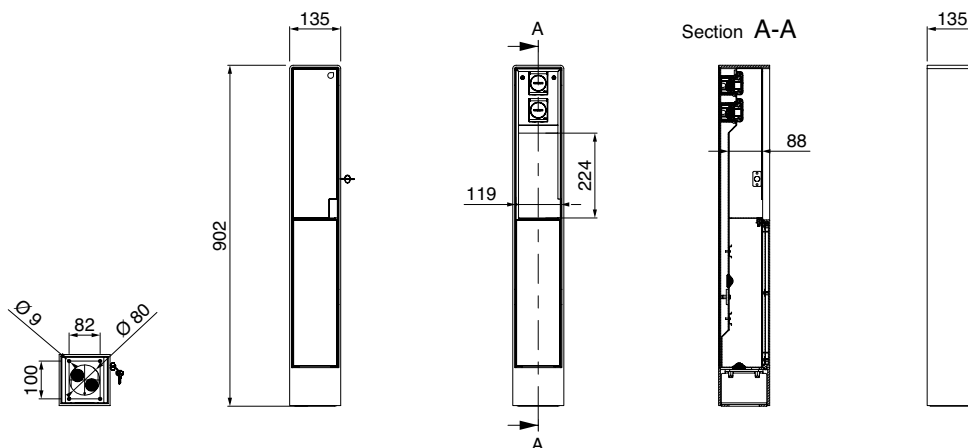

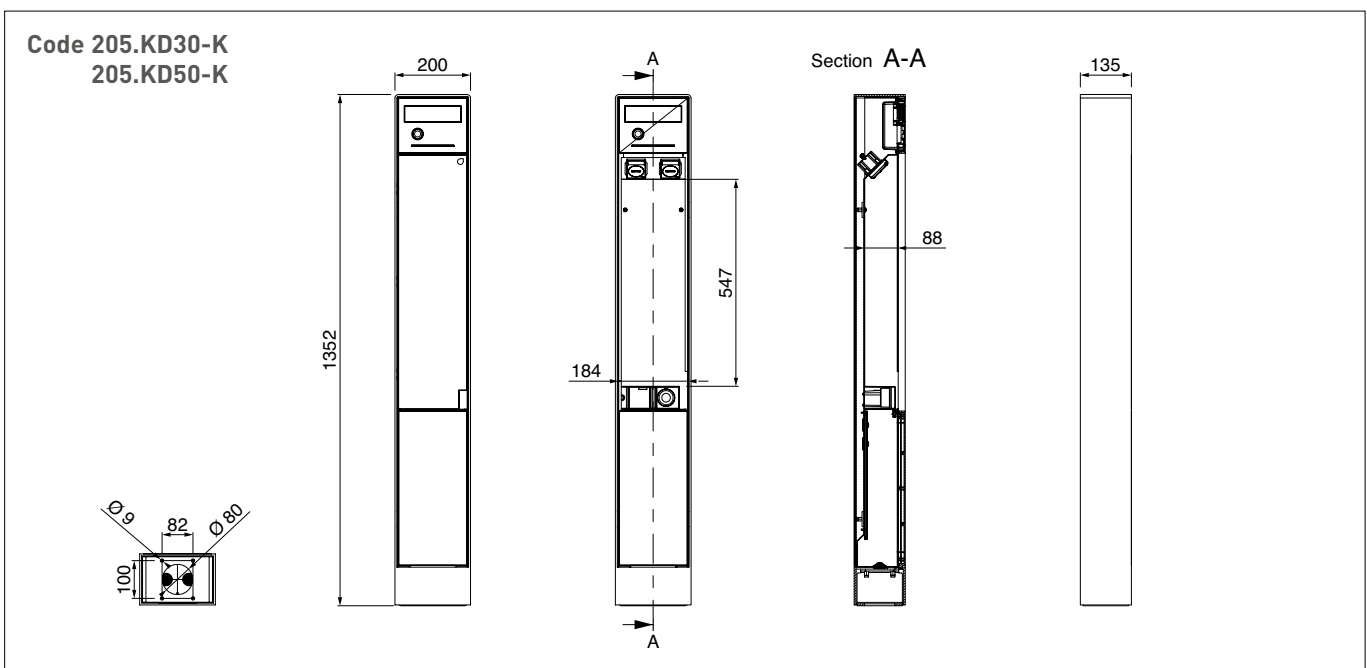
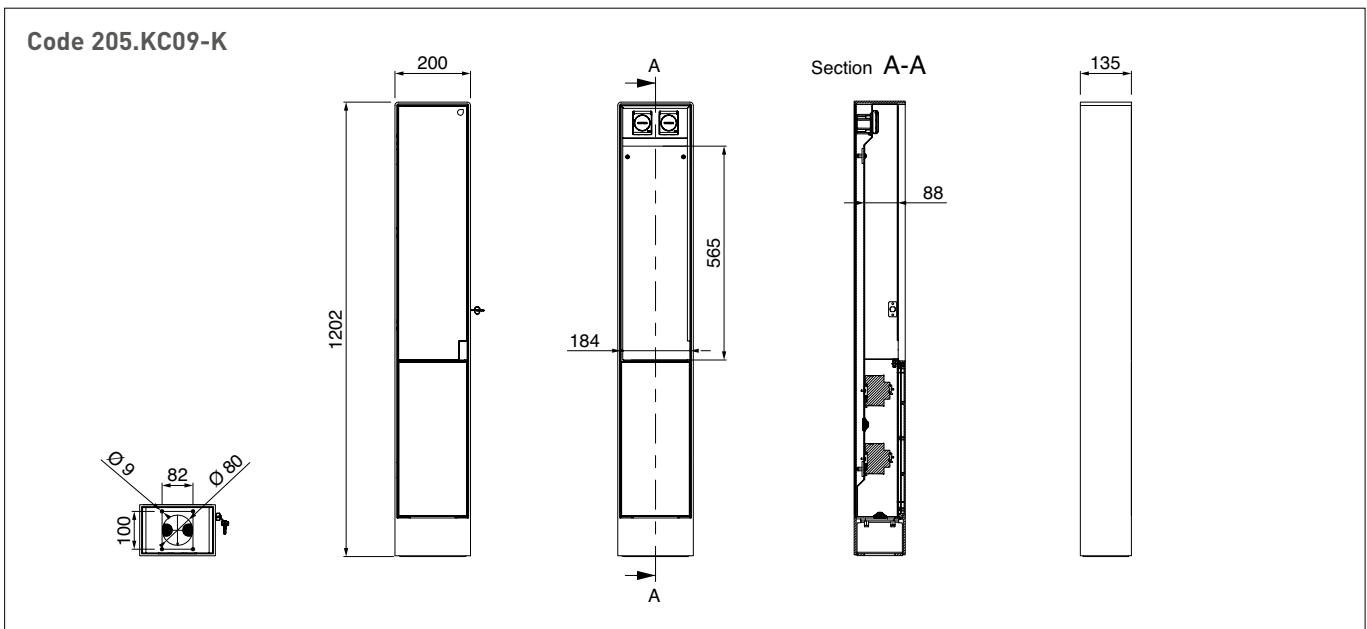
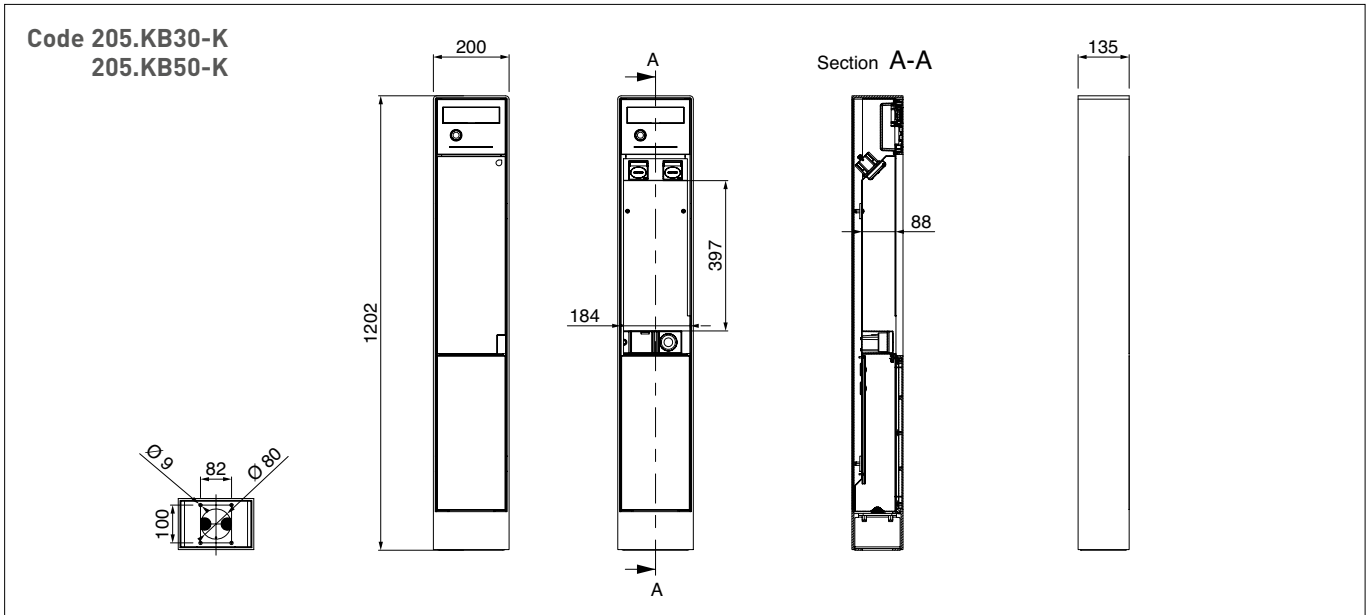

ZP01192-EN-1
8 001636 416649



SCAME PARRE S.p.A.
Via Costa Erta, 15 - 24020 Parre (BG) Italy
Tel. +39 035 705000 - Fax +39 035 703122



www.scame.com
export@scame.com

